

# CV-110/P1001E

10.4" TFT SVGA 4:3 Touch Panel PC, with Intel® Atom™ E3845 Quad Core, 4x USB, 2x COM, 1x VGA, 1x DisplayPort and 2x Universal I/O Bracket



## Key Features

- 10.4" TFT SVGA 4:3 LCD with Resistive 5-wire / Projected Capacitive Touch
- Designed with Aluminum Die-Casting Front Frame
- Onboard Intel® Atom™ E3845 Processor Quad Core, 1.91GHz
- 1x DDR3L SO-DIMM max. up to 8GB
- 1x 2.5" SATA HDD Bay, 1x CFast Card and 1x SIM Card Socket
- 2x LAN, 4x USB, 2x COM, 1x VGA, 1x DisplayPort, 4x DI/4x DO
- 1x Mini-PCIe Expansion Socket
- 2x Universal I/O Brackets
- IP65 Compliant Front Panel
- Support Panel / Wall / Arm / VESA Mounting
- Convertible Display System (CDS) Supported
- Built-in Two 2W Internal Speakers

## »» Overview

The 10.4" all-in-one panel PC offers LED backlight LCD with resolution up to 800x600 (SVGA) and 400 nits brightness. CV-110/P1001E features flat surface and IP65 dust/waterproof front panel. In addition, designed with aluminum die-casting front frame with rugged body structure that can be able to apply in industrial applications. CV-110/P1001E supports Convertible Display System (CDS) technology which makes it more flexible in system maintaining and upgrading. CV-110/P1001E carries single touch function with resistive 5-wire touch screen. By incorporating with Intel® Atom™ E3845 processor and DDR3L memory, CV-110/P1001E offers extensive I/O including 4x USB, 2x RS-232/422/485, 1x VGA, 1x DisplayPort, 4x DI / 4x DO and 2x Universal I/O Bracket.

CV-110/P1001E supports 3G and WLAN via 2x GbE and 1x Mini-PCIe slot. Furthermore, they are 3 types of storage devices including 2.5" SATA HDD, CFast and SIM card. The accessible design of these storage devices allow quick data access and easy maintenance. Supporting wide range power DC input from 9 ~ 48VDC, CV-110/P1001E can be deployed and powered for various industrial applications.

## »» Specifications

### Display

- LCD Size: 10.4" [4:3]
- Max. Resolution: 800 x 600
- Brightness (cd/m2): 400
- Contrast Ratio: 700 : 1
- LCD Color: 16.2M
- Pixel Pitch (mm): 0.264 (H) x 0.264 (V)
- Viewing Angle [H-V]: 160 / 130
- Backlight MTBF: 50,000 hrs (LED Backlight)

### Touch

- Resistive 5-wire Touch for CV-110R/P1001E Only
- Projected Capacitive Touch for CV-110C/P1001E Only

### Processor

- Onboard Intel® Atom™ Processor E3845 Quad Core, 1.91 GHz with AMI 64Mbit SPI BIOS

### Memory

- 1x 204-Pin SO-DIMM DDR3L 1066 / 1333MHz (un-buffered and non-ECC), max. up to 8GB

### Storage

- 1x External 2.5" SATA HDD Bay
- 1x External CFast Socket
- 1x External SIM Card Socket

### External I/O Interface

- 1x VGA
- 1x DisplayPort
- 1x USB 3.0
- 3x USB 2.0
- 2 x Intel® i210-AT GbE LAN Port (Support Wake-on-LAN and PXE)
- 2x DB9 for COM1~2 (Support RS-232/422/485 with Auto Flow Control)
- 1x 4 Isolated DI & 4 Isolated DO Port
- 1x Line-out
- 1x Mic-in
- 1x Power Switch
- 1x Reset Button
- 1x AT/ATX Switch

**Digital Input & Output**

- 4x Digital Input (Source Type)
  - Input Voltage (Dry Contact):
    - Logic 0: Close to GND
    - Logic 1: Open
  - Input Voltage:
    - Logic 0: -3V (Min/DI to COM+)
- 4x Digital Output
  - Supply Voltage: 5-30VDC
  - Sink Current: 580mA Max.
  - DIO Max.: 30V

**Expansion**

- 1x Full-size Mini PCIe Socket for Wi-Fi / GSM / Expansion Module
- 2x Universal I/O Brackets

**Watchdog Timer**

- Software Programmable Supports 1-255 sec. System Reset

**Power Requirement**

- Support AT, ATX Mode
- 1x 3-pin Terminal Block Connector with Power Input 9-48VDC
- 1x Optional AC/DC 12V/5A, 60W Power Adapter

**Environment**

- Operating Temperature: Ambient with air flow: -20°C to 70°C (with Industrial Grade Peripherals)
- Storage Temperature: -30°C to 80°C
- Relative Humidity: 90% RH @ 40°C (non-condensing)
- IP Level: IP 65 Compliant Front Panel

**Physical**

- Dimension (WxHxD): 295 x 227.3 x 87.85 mm
- Weight: 3.78 kg
- Construction Front Panel: Die-Casting Flat Surface
- Mounting: Panel / Wall / Arm / VESA Mounting

**Operating System**

- Windows® 10
- Windows® 8.1
- Windows® 7
- Linux® Kernel 3.X

»» External I/O Mechanical Layout

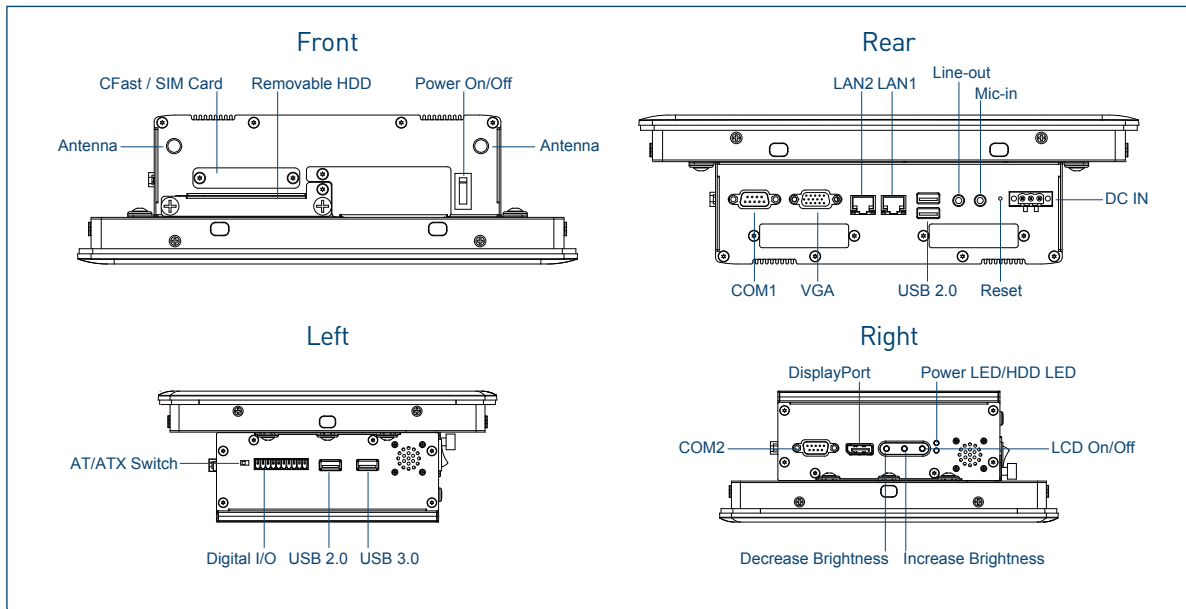

»» Dimensions

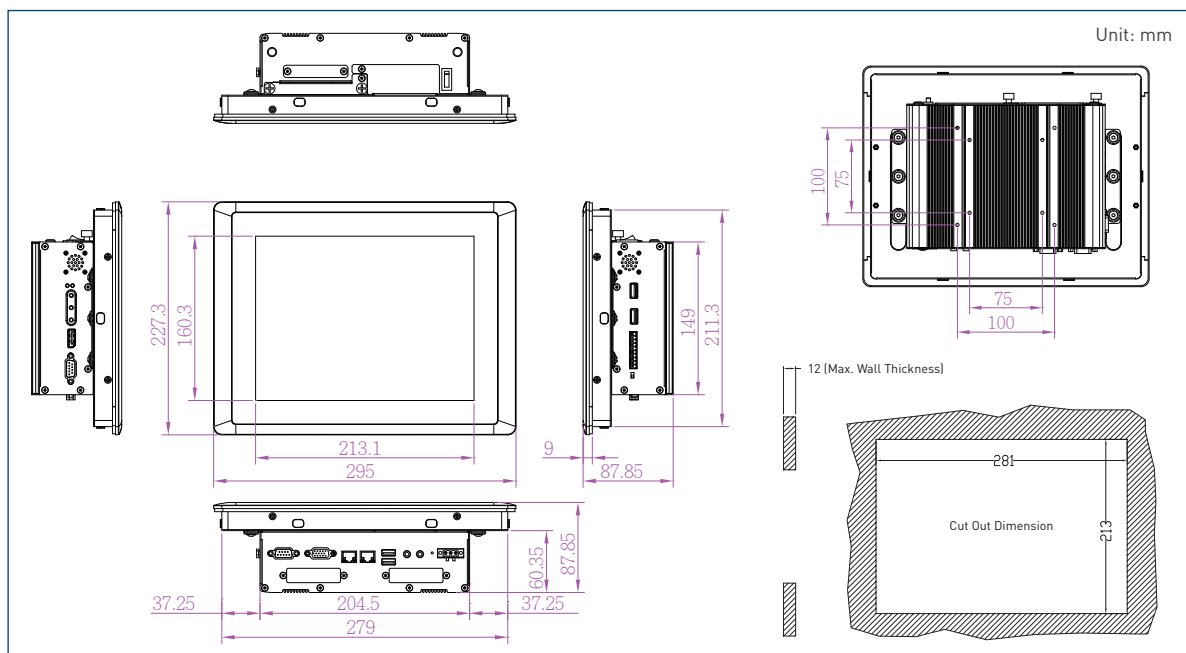

## >>> Ordering Information

### Available Models

Model No.	Product Description
<b>CV-110R/P1001E</b>	10.4" TFT SVGA 4:3 Panel PC with <b>Resistive 5-wire Touch</b> , with Intel® Atom™ E3845 Quad Core, 4x USB, 2x COM, 1x VGA, 1x DisplayPort and 2x Universal I/O Bracket
<b>CV-110C/P1001E</b>	10.4" TFT SVGA 4:3 Panel PC with <b>Projected Capacitive Touch</b> , with Intel® Atom™ E3845 Quad Core, 4x USB, 2x COM, 1x VGA, 1x DisplayPort and 2x Universal I/O Bracket

### Package Checklist

#### CV-110/P1001E

- CV-110/P1001E Panel PC x 1
- Panel Mounting Kit x 1
- Utility DVD Driver x 1
- DIO Terminal Block Connector x 1
- Power Terminal Block Connector x 1
- HDD Screw Pack x 1
- Mini PCIe Screw Pack x 1

### Optional Accessories

Model No.	Description
GSM60A12-CIN	Adapter AC/DC 12V 5A 60W with 3pin Terminal Block Plug 5.0mm Pitch, GSM60A12-P1J
SL2-SL3	US 2 heads power cord, US B type to IEC C13, SVT 18AWG/3C Black 1.8M SL-2+SL-3
SL6-SL3	EU 2 heads power cord, EU G type to IEC C13, H05VV-F 0.75mm2/3G Black 1.8M SL-6+SL-3
QP026-SL3	UK 2 heads power cord, UK I type to IEC C13, H05VV-F 0.75mm2/3G Black 1.8M QP026+SL-3